

TUCKER

ASSEMBLY GUIDE



Welcome!

Congratulations on becoming an owner of a premium Somerzby product! We hope it brings you and your pet/s many years of enjoyment and contentment.

When your flat pack arrives, please check all items for any damage that might have occurred in transit.



02 4340 4200

info@somerzby.com.au

What you will need



You'll need a flat, level surface to ensure proper alignment during assembly. An Allen key is provided with the screws.

Important Things To Note



- The instructions and screws can be found together in clear packaging.
- When completing Steps 1-3, make sure that Part Q is screwed on before moving to the next step.
- There is only ONE type of screw for the whole build.

Check list

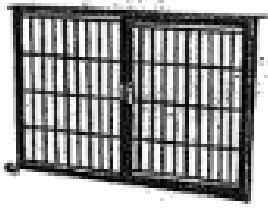

A 2 PCS

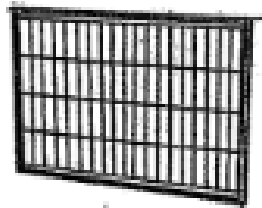

B 2 PCS

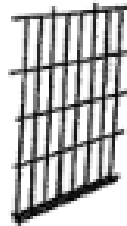

C 4 PCS

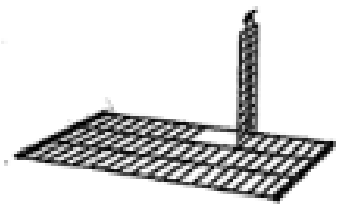

D 2 PCS

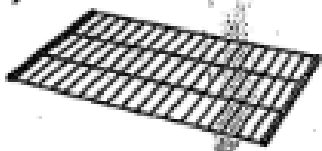

E 1 PC



F 1 PC



G 1 PC

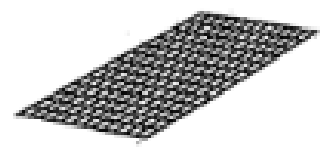

H 2 PCS

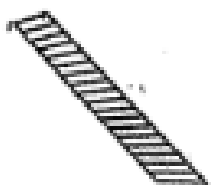

I 3 PCS



J 2 PCS

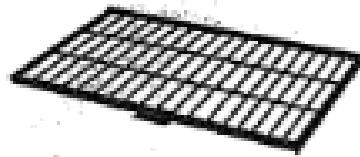

K 1 PC

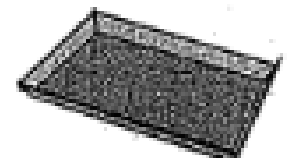

L 1 PC



M 4 PCS



N 24 PCS

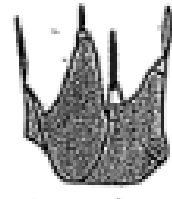

O 1 PC

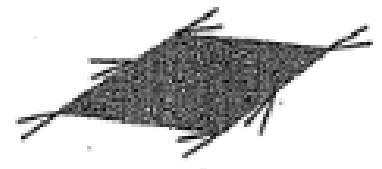

P 1 PC



Q 8 PCS

How to Assemble the Tucker Step 1 (the Base)

PARTS

Parts required for step 1:

E, F, G, J x2, M x4, Q x4

Screws:

N x 8 + Allen Key

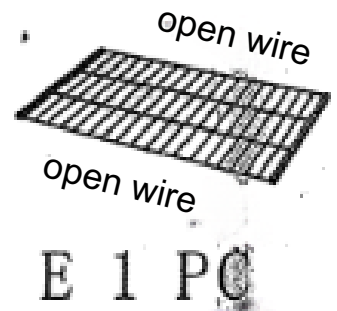

Assemble the Base

Attach Part E to F & G:

E - open wire on long sides, solid metal on short ends. Align the open wire edge of E to F's lower edge with the 4 holes. Use an Allen Key and N x 2 to attach the solid metal edge on E to F.

Repeat with G, which has the top corners covered with metal. Flat side of G faces out, not inside. Use an Allen key and N x 2 to attach the parts together.

Attach Part J & Q:

Note: The purpose of Q is to join the base with Level ONE, then Level ONE with Level TWO.

Right side: Place Q x 1 (the bottom hole) on top of the hole on F with the solid part on the right side. Facing F align J to look like a '3' facing inwards behind the top hole on F.



When both J & Q are aligned with F, put N x 1 through Q then F into J and screw together.

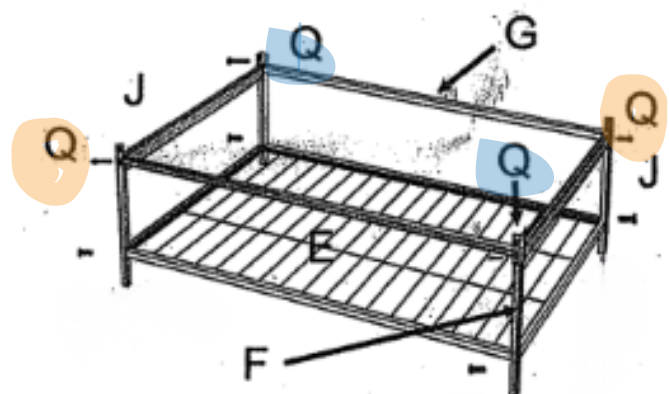

How to Assemble the Tucker Step 1 (the Base)

Left side: J looks like the letter “E” and Q’s solid side on the left. When both J & Q are aligned with F, put N x I through Q then F into J and screw together.

Facing G repeat the above for attaching G and Q to J. Use N x 2 to screw together.

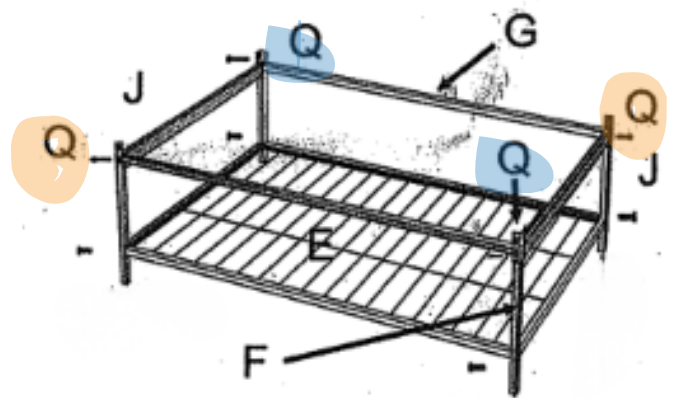
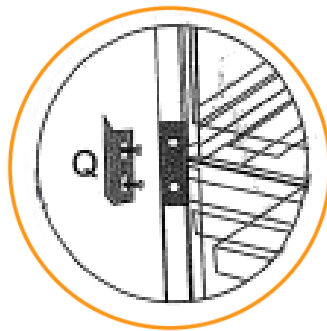

Attaching the Wheels to the Base:

Attaching Part M:

Flip the assembled base to access the base of F & G. The long metal part of M is to be pushed into the hole in the legs’ of F & G. The top of the metal cap covering the wheels is to be flush with the ‘leg’ of F and G. Attach all four M parts.



Flip right way up for STEP 2.

How to Assemble the Tucker Step 2 (First Level)

PARTS

Parts required for step 2

Assembled Base + A, B, C x2, D, Q x4,

Screws;

N x 8, Allen Key

Assemble the Front and Sides for Level ONE:

Attach Panel A & C with Q:

Part A FRONT SIDE has the door on the right and on the BACK SIDE in the top corners should be two holes close together and one hole in the base corners. The short sides have a total of 6 holes, including the corner holes on the BACK.

Align the FRONT base edge on top of F behind Q. Hold and align the metal base of C onto J behind A. The open wire spikes on C fit into the holes on A's BACK.

Put I x N in the top hole of Q, through A into C and screw together. Use Allen key to tighten.

Repeat on the other side.

Note:

If Q's top hole doesn't line up with A properly, you may need to loosen the bottom screw and move up or down into the correct spot.

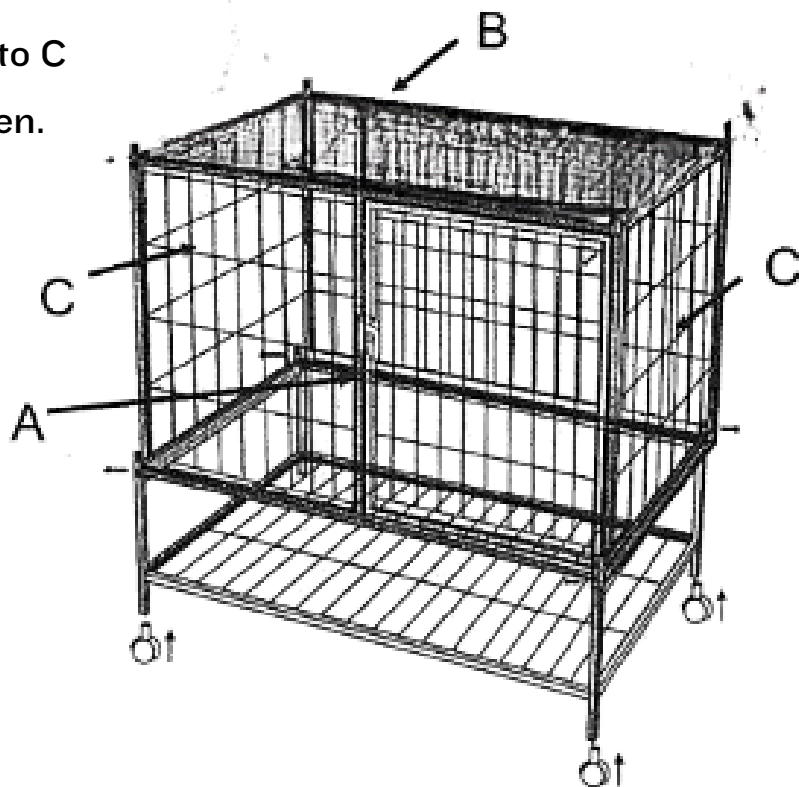

How to Assemble the Tucker Step 2 (First Level)

PARTS

Parts required for step 2

Assembled Base + A, B, C x2, D, Q x4,

Screws;

N x 8, Allen Key

Assemble the Back and Roof for Level ONE:

Attach Panel B:

Part B BACK SIDE is the same as Part A. Align the base of B between the 2 x C's and Q's, on top of G. The wire spikes on C fit into the holes on B's BACK.

Put 1 x N in top hole of Q, through B into C and screw together for each side. Use Allen key to tighten.

Attach Panel D:

The short sides have two holes on one side and none on the other. Face the side with holes down. The door needs to be next to part B. The wire spikes on D need to be maneuvered into the TWO holes on parts B and A. The spikes from C should fit into place within the holes on the short metal side of D.

Next, we need Q and repeat from step 1 to attach D to A and B through Q.

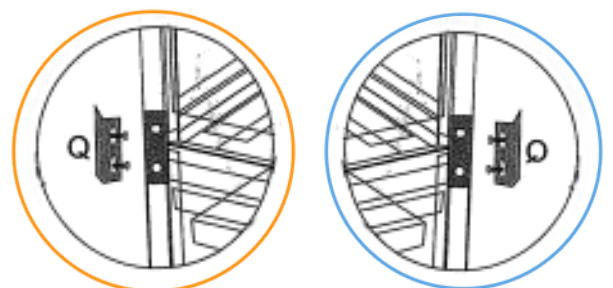
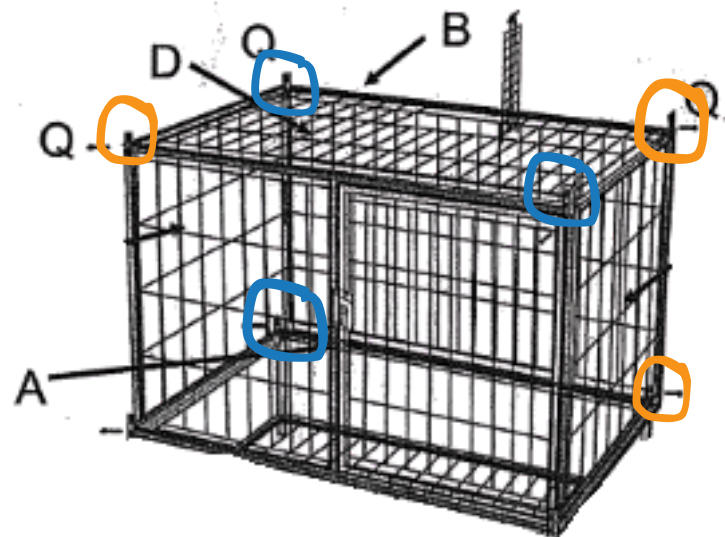

How to Assemble the Tucker Step 3 (Second Level)

PARTS

Parts required for step 3

A, B, C x2, D,

Screws;

N x 8, Allen Key

Repeat the Following from Step 2 for Level TWO

- **Attach Panel A & C with Q**
- **Attach Panel B**

Note: Ignore Q parts from Step 2, they're not needed in STEP 3.

Attach Panel D:

The short sides have two holes on one side and none on the other. Face the side with holes down. The door needs to be next to part B.

The wire spikes on D need to be maneuvered into the TWO holes on parts B and A. The spikes from C should fit into place within the holes on the short metal side of D.

Use N x 4 to secure Parts D to A and B.



How to Assemble the Tucker Step 4

PARTS

Parts required for step 4:

H x 2, I x 3, K, L, P, O

Assemble the Shelves and Ramps:

Slide K (wire tray) into the top section of part J's rails. Move the hanging tab out of the way when inserting.

Slide L (plastic tray) directly underneath K in the bottom section of the rails.

Open the door on A and hook H onto the middle horizontal wire as close to the left wall in levels ONE and TWO.

Hook part 'I' onto H as close to the edge and to the door on A as possible for each level.

On Level TWO open the door that is part of the floor, all the way till it's flat towards the right.

Hook the last 'I' part to the wire floor under where the door was just moved. The base of that ramp will land on Level ONE's H.

Attach parts P and O wherever you would like.

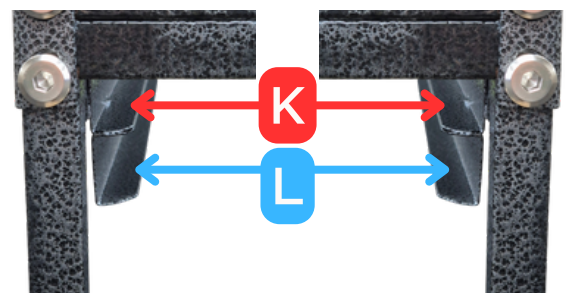
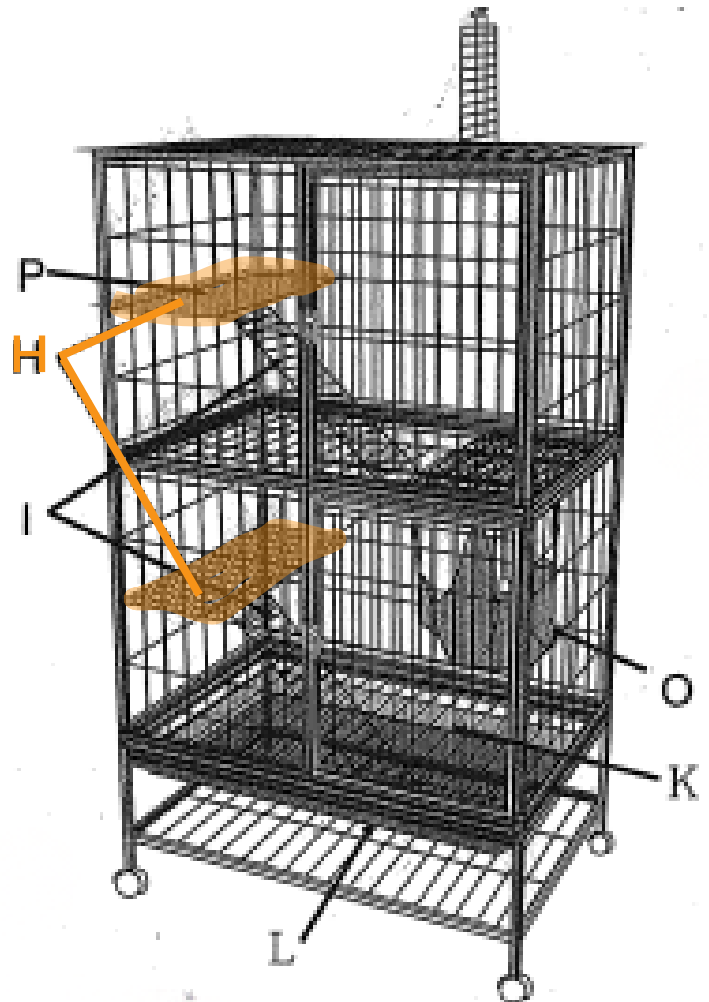

FINISH





FAQ

Frequently asked questions

Contact Information

Phone: 02 4340 4200

Email: info@somerzby.com.au

Customer Service Office Hours

Monday – Thursday: 9:00am – 4:30pm

Friday: 9:00am – 4:00pm

Saturday & Sunday: Closed

Public holidays: Closed

www.somerzby.com.au

somerzby

